

Kent Demarcation Stud



Kent
STAINLESS

Specify:

Kent Road Demarcation Stud KRDS100; Grade 316L Stainless Steel; Cold Rolled Electro-polished; Laser cut bike symbol.

The Kent Road Demarcation Stud KRDS100 is used mainly in car park areas to mark out spaces, it is a very modern and innovative design. The stud is manufactured from Grade 316L Stainless Steel with a Bright Satin finish. It has an overall diameter of 100mm, this makes it easily visible for pedestrians and oncoming drivers. Once installed the stud lies 10mm above the surface at a 150 degree angle. The stud comes with a plain top as standard but an option available is to have a logo or symbol laser cut into the top and to be placed on a vinyl colour of choice as seen in the photos.

Features:

- **Grade 316L Stainless Steel**
- **100mm overall diameter**
- **Bright Satin Finish** 
- **Optional Laser cut logo**
- **Vinyl back colour**

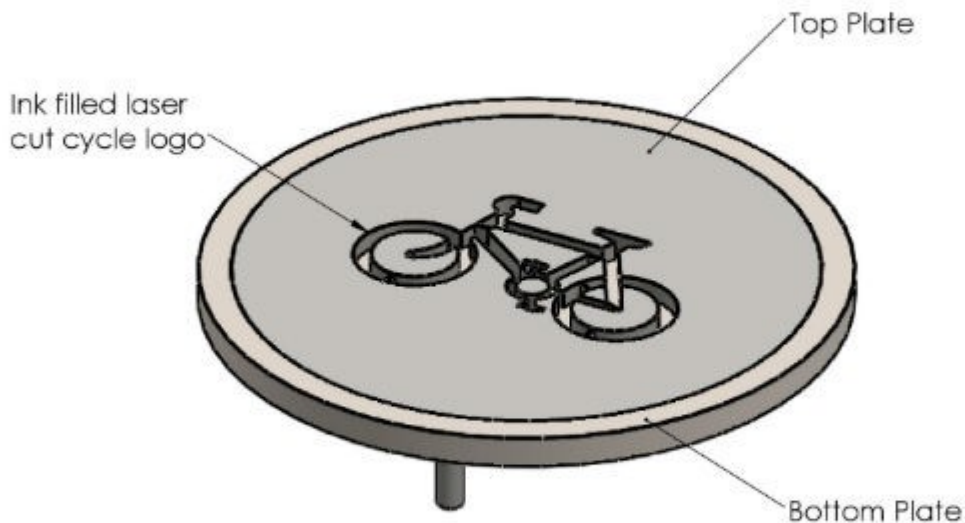

KENT ROAD DEMARCATIION STUD (KRDS 100)

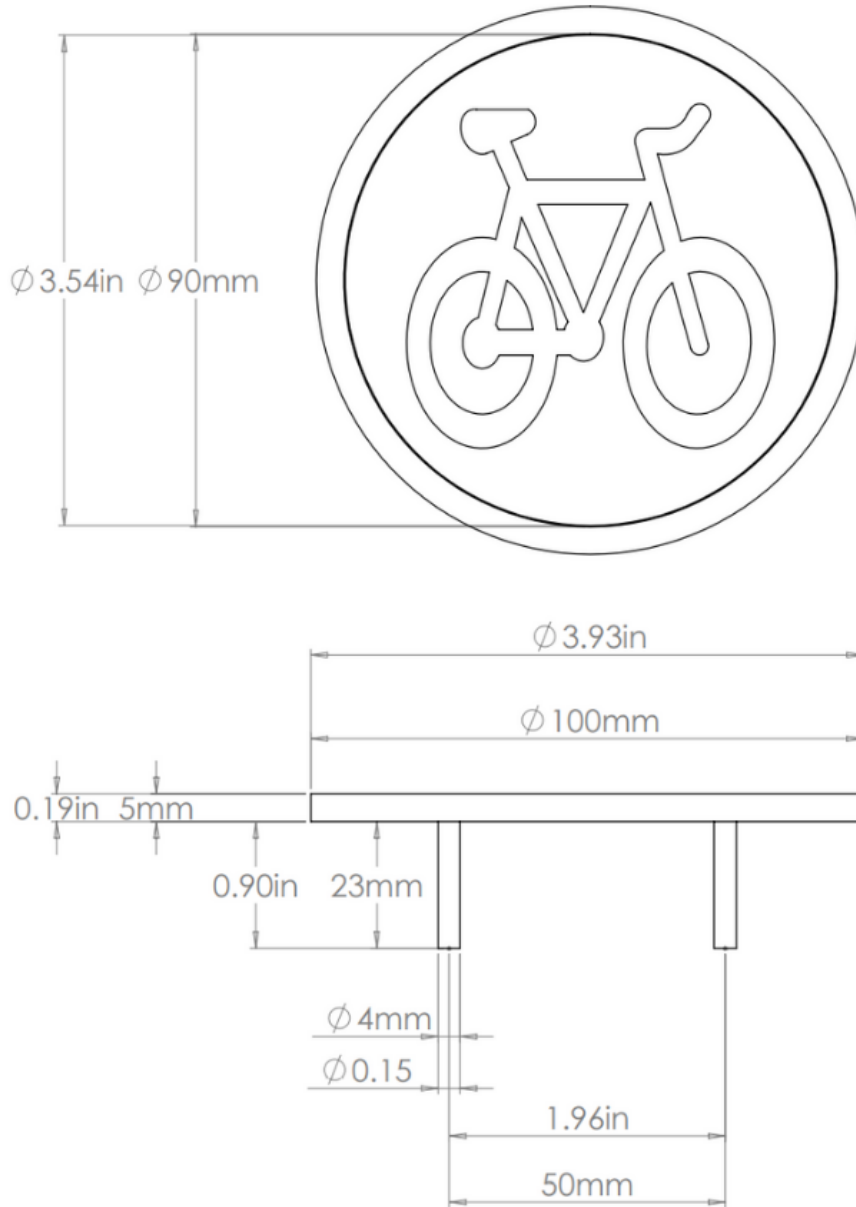

| Product Code | Height | Diameter | Inner Plate Diameter |
|-------------------------------------|--------------|---------------|----------------------|
| Kent Road Demarcation Stud KRDS 100 | 0.98" (25mm) | 3.93" (100mm) | 3.54" (90mm) |

Installation of Studs

Step 1:

Drill a 0.59" (15mm) Diameter hole 1.18" (30mm) deep.

Step 2:

Clean out the drilled hole.

Step 3:

Fill with chemical mortar (Kent Stainless recommend MIT-SE Mortar).

Step 4:

Insert Stud and leave to set for 24 hours

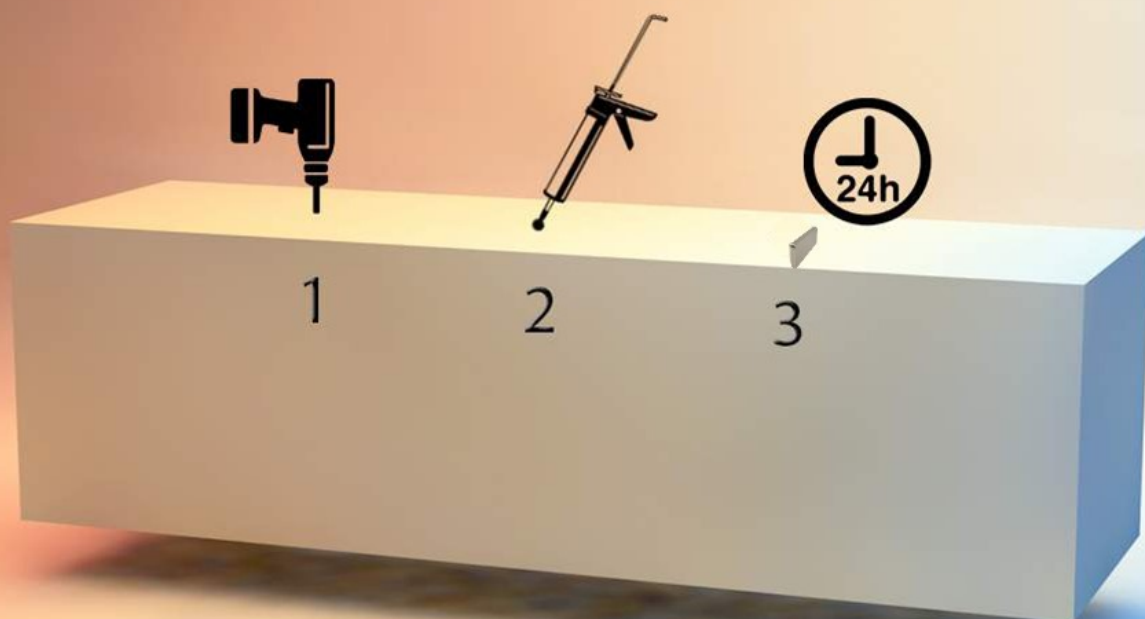

Maintenance of Stainless Steel

How often?

For an area that receives regular rainfall that washes away the build up of salt deposits, cleaning should be done once a year. If rainfall cannot get to certain areas, but still salt and pollution deposits can blow onto it (e.g. the underside of a tram shelter) then cleaning should be done 1-2 times a year in urban environments and 3-4 times a year in marine environments. In a particularly severe environment with pollution and salt deposits and wind with little rainfall, cleaning should be done 4-12 times per year.

Judge your cleaning regime by the nearby glass panels or window cleaning and clean the stainless as often as the glass nearby.

How do I do it?

For regular cleaning, and for a preventative regime, a simple wipe down by soft cloth or sponge with a mild detergent is enough (e.g. 5% dilution of wash-up liquid). Rinse off with de-ionised water or bottled drinking water is fine if this is not readily available. Rub dry with a clean dry cloth rather than letting the product drip dry.

If staining does not disappear, switch the soft cloth to a pad of Scotchbrite™ from 3M™. Use the soapy water with Scotchbrite™ vigorously on areas that are unpolished or not architecturally important. For polished areas of products with a grain (e.g. Satin Finish 320 Grit Polish), rub gently forwards and backwards only in the direction of the grain direction so proceed with caution if this is an architecturally important feature.

Again – rinse with de-ionised water and dry with a soft cloth. For heavier staining or contamination by iron products Kent recommend Avesta cleaning chemicals. Cleaner Avesta 401™ can be used instead of the mild detergent as above. Avesta 420™ Fingerprint remover is a good cleaner to for areas prone to public fingerprints – it must be sprayed on and rubbed in while wet.

Pickling Gel Avesta 130™ (hazardous) and Passivator Avesta 630™ can be used for large, important features, but these should be discussed and a method statement is available from Kent Stainless for their use. This work can be sub-contracted to Mister Stainless™ in Ireland and Edimex™ in Dubai.



Kent Stainless Ltd
Ardcavan, Wexford, Ireland

TEL NO: +353 53 9143216
UK FREEPHONE: 0800 376 8377
FAX: +353 53 9141802
WEB: www.kentstainless.com
EMAIL: info@kentstainless.com

